

MASTER TECHNICIANS SERVICE CONFERENCE

**REFERENCE
BOOK**

70-9

BRAKE HYDRAULICS



PLYMOUTH • DODGE • CHRYSLER
IMPERIAL • DODGE TRUCK

Front Cover

Introduction Page

Page 1 - Table Of Contents

Page 2 - Master Cylinder Information

Page 3 - Disc and Drum Master Cylinders

Page 4 - Ports - Compensating and Filler

Page 5 - Pressure Loss In Hydraulic Systems

Page 6 - Cover And Gasket, Diagnosis And Service

Page 7 - Use Manuals And Bench-Bleeding

Page 8 - Hydraulic Brake System Controls

Page 9 - Safety Switch Information

Page 10 - Proportioning Valve

Page 11 - Floating Caliper Disc Brakes Needs A Metering Valve

Page 12 - Bleeding With A Metering Valve

Page 13 - 1970 Master Cylinder Identification Chart

Back Cover

With the advent of today's modern freeways, a lot of people are doing a considerable amount of high-speed driving in their everyday lives. Most of the time traffic moves along at a pretty steady pace. Of course, during rush hour – and for that matter, at any time – freeway driving can become bumper-to-bumper, stop-and-go within seconds. What I'm trying to say is that on the freeways, "whoa" power is just as important as "go" power. It's even more important for those emergency situations that require extremely heavy braking.

The brakes are one of the most important safety devices on any vehicle. And, if the brakes are working right, the driver can count on a safe, sure stop every time. He relies on his brakes for his own safety and the safety of others. This month's session covers the complete "how it works" story on the latest Chrysler brake hydraulic systems – both drum and disc. If you understand the fundamentals, it's easier to follow the diagnosis and service tips that are included in this reference book.

Since our last session on the brake hydraulic system, there have been some changes and improvements made to both the drum and disc brake systems. There's nothing overly complicated about these changes and you won't have any trouble understanding them if you take the time to read this reference book carefully and thoroughly.

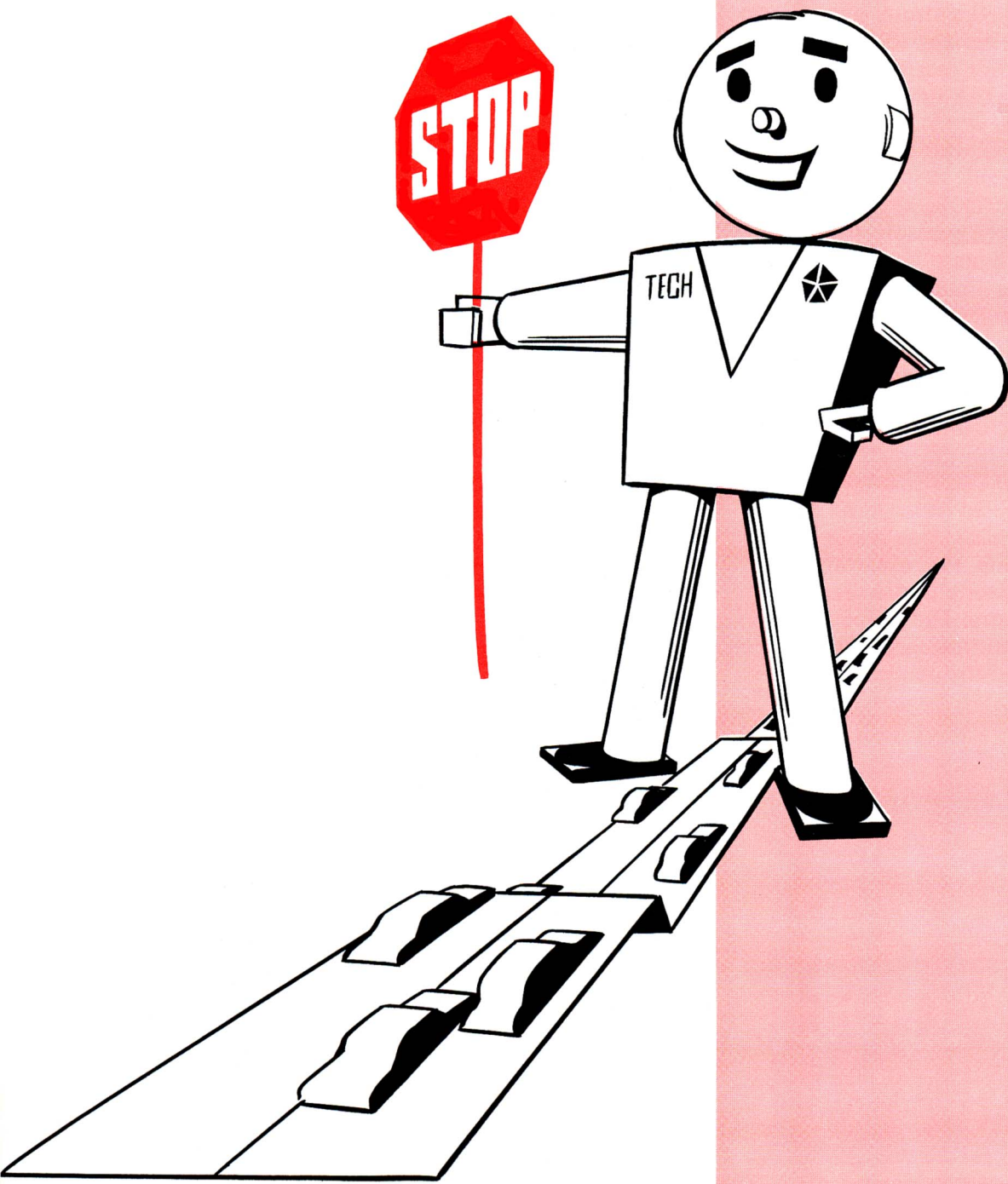
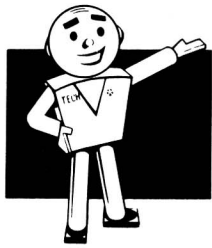

TABLE OF CONTENTS:

MASTER CYLINDER 2
HYDRAULIC BRAKE SYSTEM CONTROLS .. 8





MASTER CYLINDER

Although the drum and disc brake systems have different devices to control the pressure to either the front or rear brakes, it all starts at the master cylinder. The master cylinder is the supply house for the hydraulic fluid. It is designed to separate the hydraulic systems for the front and rear brakes, to insure that loss of pressure in one system won't result in loss of pressure in the other.

TWO 'N' ONE EQUALS ONE

The tandem master cylinder has two separate fluid reservoirs arranged one behind the other in one housing and two separate pistons that operate in tandem in a single cylinder bore. The piston at the front of the master cylinder creates hydraulic pressure to the rear brakes and the rear piston does the same for the front brakes.

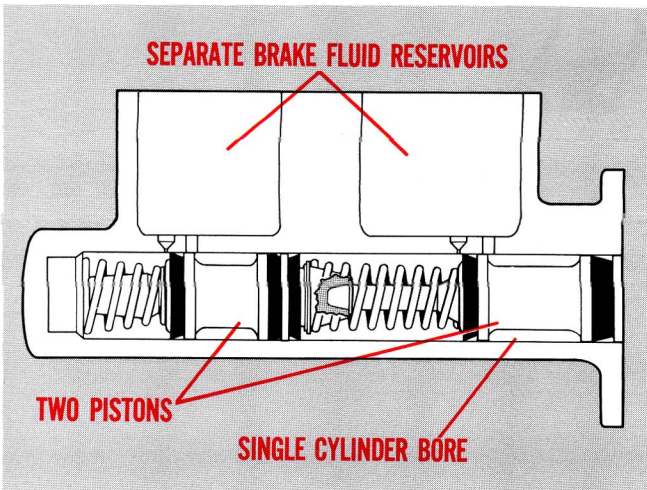

Fig. 1—"Tandem" means one behind the other

PRIMARY AND SECONDARY

It's easier to keep things straight if you think of the rear piston as the *primary* piston since it is actuated directly by the brake pedal or the power booster. In addition, the primary piston supplies hydraulic pressure to the front brakes where most

of the braking power is needed. It stands to reason that the front piston is the *secondary* piston and supplies pressure to the rear brakes. Whereas the primary piston is operated *mechanically* the secondary piston is operated *hydraulically* by pressure from the primary piston. So actually, the secondary piston is a *slave* piston.

NO CHANCE OF A GOOF

If you have any trouble remembering which is which, the brake line fitting nuts at the front and rear outlets are different sizes. This eliminates the possibility of connecting a brake line to the wrong outlet. The outlets are also marked "F" and "R" to designate which set of brakes it serves. You can't get much more "goof-proof" than that.

RETURN SPRINGS

Here's what happens inside the master cylinder. Each piston has a return spring ahead of it to position the piston cup slightly to the rear of the compensating port in each reservoir. In addition to keeping the compensating ports uncovered, the return springs also return the brake pedal. The compensating ports will be covered in detail later along with the filler ports.

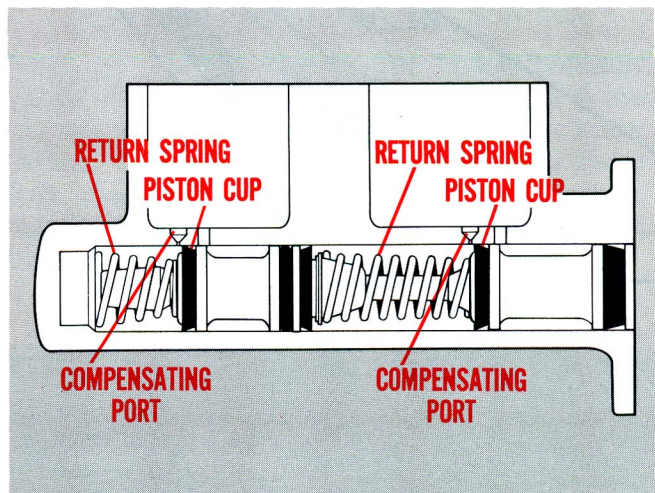

Fig. 2—Springs return piston and brake pedal



HOW MASTER CYLINDER BUILDS PRESSURE

When the brakes are applied, the stiffer primary spring pushes the secondary piston forward, compressing the secondary spring slightly. The cup at the front end of the secondary piston passes and closes off the secondary compensating port. Pressure in the secondary portion or chamber starts to build up. At the same time, the piston cup on the primary piston has closed off the primary compensating port. Since fluid is now trapped in front of each piston, further pedal movement builds pressure in both the primary and secondary.

HYDRAULIC LINK BETWEEN PISTONS

During normal operation, there is a hydraulic link between the primary and secondary pistons. As I mentioned before, the secondary piston is actually a slave piston operated by pressure developed in the primary chamber. The piston cup at the rear of the secondary piston works as the “closed end” of the primary chamber; and as long as the secondary piston is free to move forward, you can’t build any more pressure in the primary than in the secondary chamber. As a result, operating pressures in both chambers are equal and front and rear brakes are applied equally.

WELL . . . ALMOST EQUAL

Actually, hydraulic pressure is proportional to the force applied to the push rod by the brake pedal . . . minus the resistance offered by the return springs. The primary return spring is slightly stiffer than the secondary spring and holds the primary piston back a little more than the secondary piston. Therefore, the secondary pressure is slightly higher than the primary pressure; however, compared to the total hydraulic pressure developed, the difference is very small.

DISC AND DRUM MASTER CYLINDERS

The disc brake master cylinder is different from the drum brake master cylinder and they cannot be interchanged. They are quite obviously different from a physical appearance standpoint; however, there are different models among both the drum and disc master cylinders. A chart at the end of this reference book lists the application, part number and identifying features for all 1970 master cylinders. The following paragraphs explain

in what ways the disc brake master cylinders are different from the drum brake master cylinders.

LARGER RESERVOIRS

The disc brake master cylinders have larger reservoirs. There really isn’t any reason for the secondary reservoir to be larger, but the primary is a different story. The primary reservoir for the disc brakes is bigger because the disc brake pistons in the calipers are larger than the drum brake wheel cylinder pistons so that more fluid is required as the disc brake lining wears away. Naturally, the larger disc brake pistons require more fluid to move them and this greater amount of fluid is supplied by the disc brake master cylinder.

ONLY ONE RESIDUAL VALVE FOR DISCS

The other difference in the disc brake master cylinders is that there is only one residual valve; and that valve *must* be in the secondary outlet at the front of the master cylinder. That’s the one for the rear drum brakes. Residual pressure in the primary brake lines would make the disc brake shoes drag and wear out prematurely. That’s because there are no brake shoe return springs with disc brakes; the piston seals act as retractors to pull the pistons back.

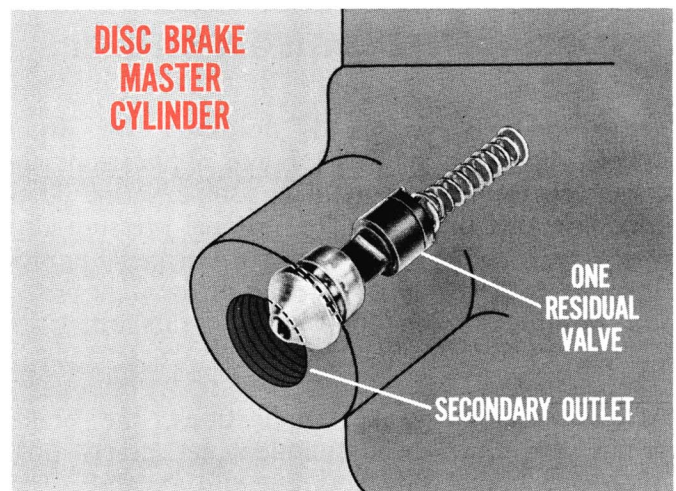

Fig. 3—Residual pressure would make disc brakes drag

WHY RESIDUAL VALVES

The residual pressure valves are located in the master cylinder outlets. They maintain a light pressure in the lines and in the wheel cylinders. If it were not for these valves, air might be sucked past the wheel cylinder cups and enter the wheel

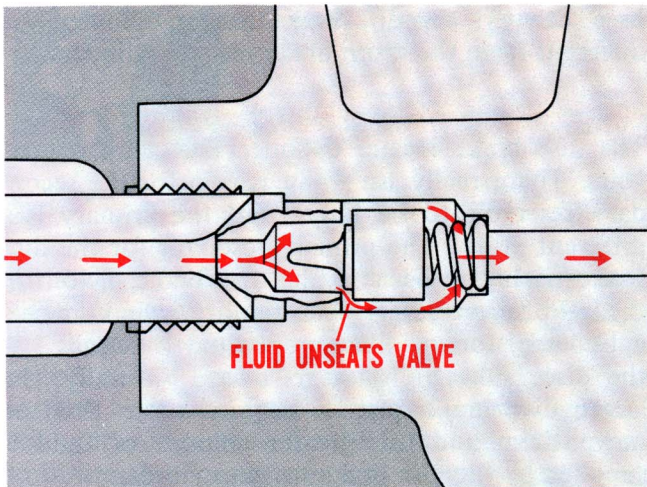

Fig. 4—Valve seats at 15 p.s.i. to maintain pressure

cylinder when the brake pedal is released rapidly. When the brakes are released, fluid flows out of the wheel cylinders and back to the master cylinder. This unseats the residual pressure valve which allows fluid to flow into the master cylinder. When fluid pressure drops to about fifteen pounds, the valve is seated and residual pressure is maintained. Residual pressure keeps the lips of the wheel cylinder cups expanded so that they press outward against the wheel cylinder bore.

PORTS—COMPENSATING AND FILLER

Light residual pressure is necessary for drum brakes, however, repeated brake application can cause too much pressure. The compensating ports eliminate this problem. The residual pressure also contributes to the action that permits pedal pump-up, but, primarily that is the job of the filler ports. Let's examine in detail how each does its job.

HEAVY BRAKING CAUSES FLUID EXPANSION

After numerous brake applications, the brake drums and the wheel cylinders get pretty hot. Then, the brake fluid gets hot and expands. The pressure buildup can become great enough to prevent the brake shoes from returning. This causes the brake shoes to drag and generate *more* heat and more pressure.

COMPENSATING PORTS DO JUST THAT

The compensating ports are small passages between the reservoirs and the cylinder bore. What they do

is allow pressure to compensate or equalize when the pistons are fully returned.

When pumping the brakes, more than the normal amount of fluid is forced into the hydraulic system and builds up pressure. When the brake pedal is released, the piston moves back far enough to uncover the compensating ports and the fluid can flow back into the reservoir and relieve the excess pressure in the lines and wheel cylinders. After the system cools and contracts, fluid can flow back into the cylinder to maintain full volume for the next application. Any air bubbles in the cylinder will also be able to bleed into the reservoir.

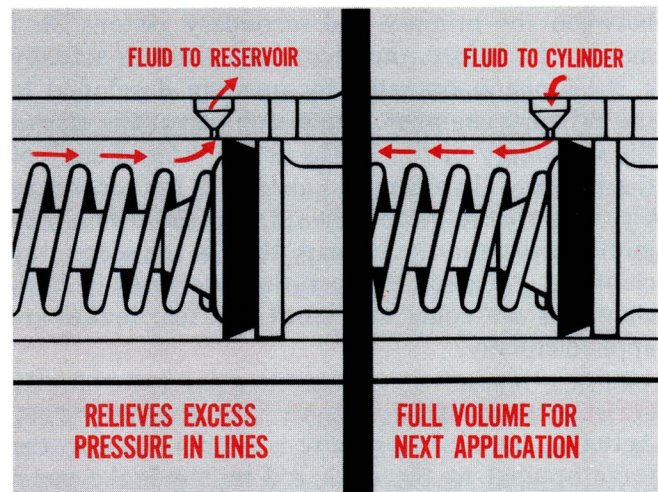

Fig. 5—Compensating ports prevent brake drag

FILLER PORTS ARE FOR PEDAL PUMP-UP

A low brake pedal is almost always due to excessive lining clearance, and that can happen through normal wear when the automatic brake adjusters aren't doing their job. However, a low pedal can also be a result of air in the brake system, low fluid level, disc brake shoes that are not flat, or severely under-ground.

The filler ports permit pumping up of the brakes if the pedal is low. If the brake pedal is pumped rapidly, the return springs in the master cylinder return the pistons quickly. At the other end, the brake shoe return springs return the wheel cylinder pistons a lot slower. The flow of fluid from the wheel cylinders is delayed and can't match the fast return of the master cylinder pistons. As a result, the master cylinder pressure drops and becomes lower than the pressure in the reservoir. Fluid is



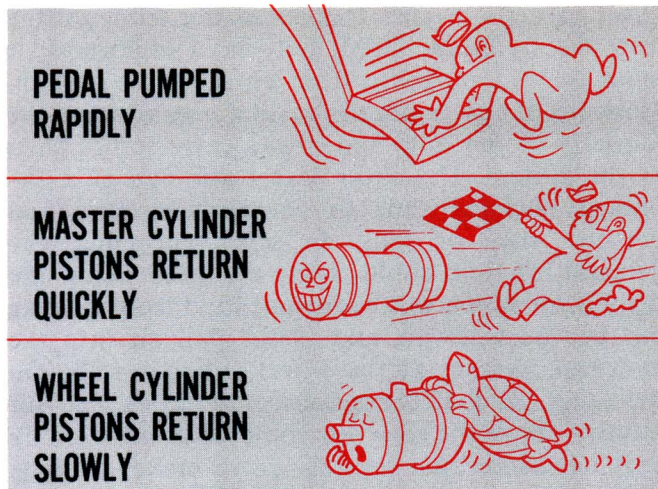

Fig. 6—Fluid flow is delayed at wheel cylinders

forced out of the reservoir by atmospheric pressure through the filler ports, through the holes in the piston, and past the piston cup. These filler ports are necessary because the compensating ports aren't big enough to handle the flow needed to pump up the pedal.

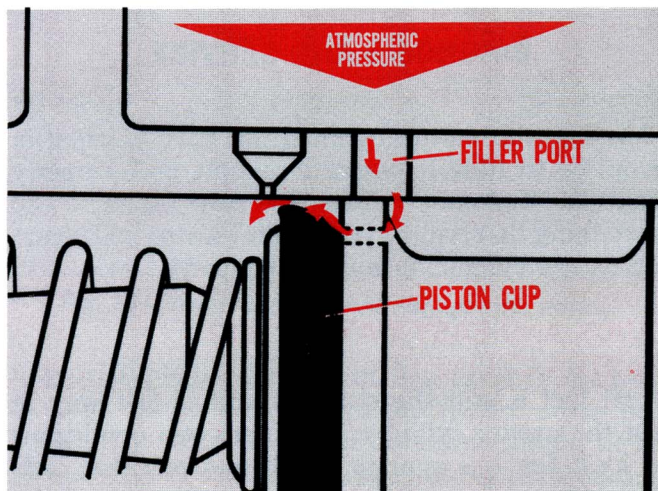

Fig. 7—Filler ports provide fluid to pump up pedal

PRESSURE LOSS IN HYDRAULIC SYSTEM

By now, you should have a pretty good idea of how the master cylinder works during normal operation. However, as mentioned earlier, the master cylinder is designed to separate the front and rear brake systems and insure that loss of pressure in one system won't result in loss of

pressure in the other system. The following paragraphs explain what happens when pressure is lost in either system.

FRONT BRAKE PRESSURE LOSS

If pressure is lost in the front brake hydraulic system, the hydraulic link is broken and there is very little pressure to resist primary piston movement. The primary piston will move forward until it bottoms against the secondary piston. Then the secondary piston is operated mechanically by the primary piston to apply the rear brakes.

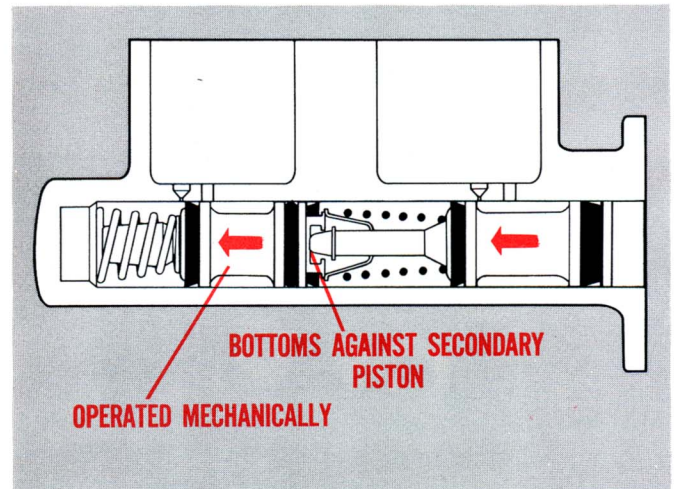

Fig. 8—Hydraulic link is broken

REAR BRAKE PRESSURE LOSS

When pressure is lost in the rear brake system, hydraulic pressure in the primary chamber, plus

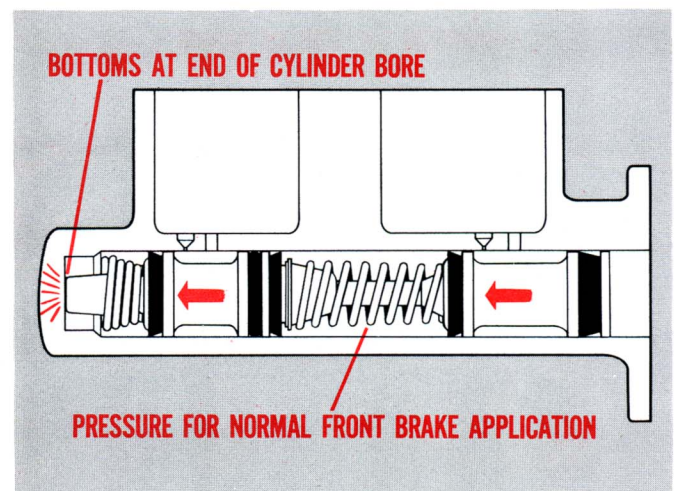

Fig. 9—When secondary bottoms, primary goes to work

spring force, pushes the secondary piston until it bottoms at the end of the cylinder bore. At that point, the primary piston begins to supply pressure for normal brake application.

COVER AND GASKET

Now that the internal parts of the master cylinder have been discussed, let's talk about the master cylinder cover and cover gasket. They are important because they provide an airtight seal while allowing the system to "breathe".

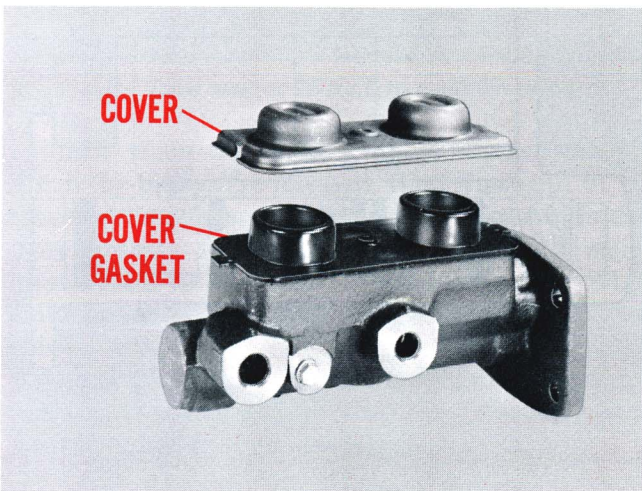

Fig. 10—Cover gasket must keep moisture out

GASKET HAS TWO JOBS

The master cylinder cover gasket's main job is to provide an airtight hydraulic system. Of course, the

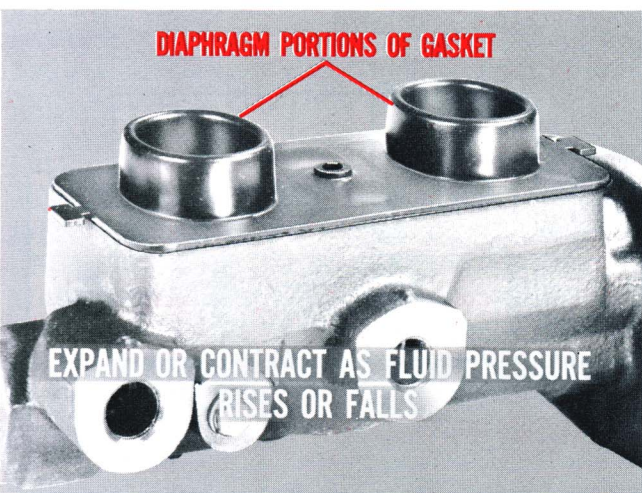

Fig. 11—Cover gasket also acts as a diaphragm

cover gasket prevents foreign matter from getting into the hydraulic fluid; but, most important, it *must* prevent moisture from entering the system. Moisture in any hydraulic system breaks down the lubricity of the fluid and causes corrosion of parts in the system. The cover gasket also acts as a diaphragm and expands or contracts as the fluid pressure rises or falls. In severe stopping, the demand for fluid could create a vacuum below the diaphragm which would prevent fluid from flowing out of the reservoir and could pull air into the hydraulic system at the wheel cylinder seals. On the other hand, if the gasket could not expand, air trapped above the reservoir could be pressurized by heat expansion and possibly cause brakes to drag.

COVER HELPS GASKET

For the gasket to be able to expand and contract, the space between the gasket and the cover must be vented. Small vent grooves or drilled holes, built into the master cylinder cover, vent the space between the cover gasket and the cover. It is just as important for these vents to let air in as it is to let it out.

DIAGNOSIS AND SERVICE

Thus far, the master cylinder has been covered in detail as to how it works to supply and properly maintain hydraulic pressure to the brakes. The next thing that will be covered is how to make sure the master cylinder is working properly.

QUICK AND EASY WAY TO TEST MASTER CYLINDER

Pedal feel is still the quickest and easiest way to test the master cylinder. There are two conditions to look for — a spongy pedal, and one that feels firm but sinks slowly to the floor. A spongy pedal usually indicates a brake system that needs bleeding, but first check the master cylinder to make sure the fluid level is high enough. A firm pedal that gradually goes to the floor usually means that the master cylinder piston seals are bad and the master cylinder should be replaced or overhauled.

INSPECT HOSES AND FITTINGS

Before you replace or overhaul the master cylinder, check the brake hoses and fittings carefully. You could be losing pressure at a loose or damaged fit-

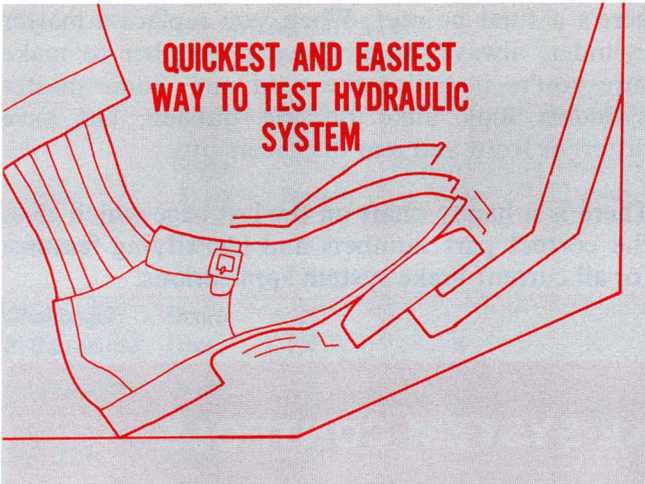

Fig. 12—There are two conditions to look for

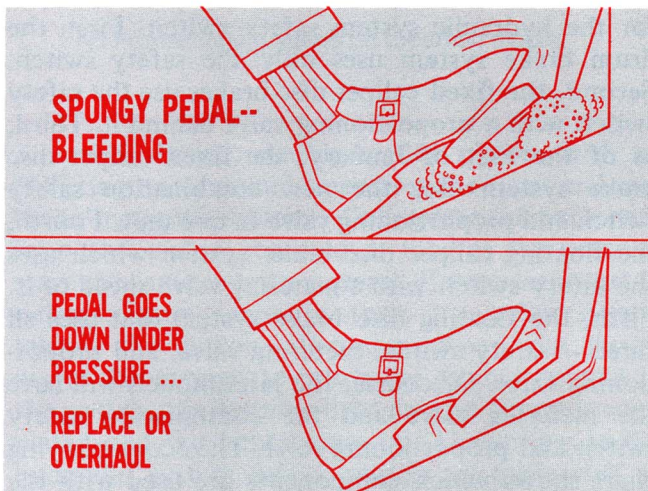

Fig. 13—Check fluid level and fittings after testing

ting or through a pinhole or fine crack in the hose or tube. Hoses which have the rubber cover perforated by nicks, cracks or abrasions should be replaced. Tubes should be checked for deformation and closeness to moving or hot parts and corrected if necessary. Any brake tubing that is replaced must be replaced with steel tubing; copper tubing is not recommended for brake line installations. Actually, it is a good practice to inspect the brake lines and fittings any time you put the car up on a lift or hoist.

USE MANUALS AND BENCH-BLEED

If you have to overhaul or replace the master cylinder, the Service Manuals are the best source for complete removal, disassembly, and installation

BLEED MASTER CYLINDER BEFORE INSTALLING

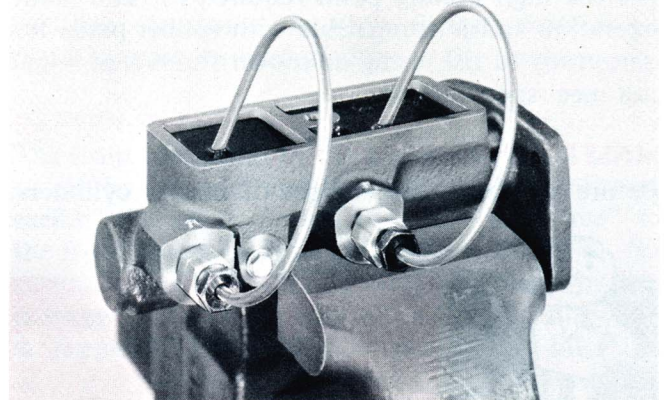

Fig. 14—Use bleeding tubes and follow Service Manual

procedures. The master cylinders for both drum and disc brakes are covered in detail. If you replace or overhaul the master cylinder, be sure to bench-bleed the master cylinder before installing it on the car. If there's air in the master cylinder, there's no point in pumping it through the whole system and out the bleeder screws. When bleeding out the brake lines, the bleed screws must be fully open. If you crack the bleed screw less than one full turn, an orifice is formed which compresses trapped air to form tiny bubbles. This condition is known as aeration and is very hard to eliminate, so be very careful to avoid causing this condition. Be extremely careful to keep the fluid level up in both reservoirs when bleeding. If it gets low, you'll pump air into the hydraulic system and have to start all over again.

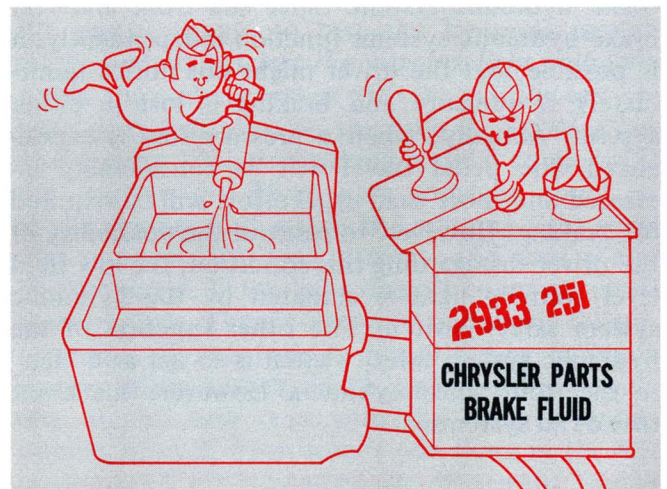

Fig. 15—Not worth the risk to use unknown fluids

USE PROPER FLUID

And be sure to use Chrysler Parts brake fluid. It has the high boiling point required for safe brake operation and is compatible with rubber parts. It's dangerous to risk using unknown fluids that might not meet specifications.

MASTER CYLINDER CHART

Before we leave the subject of master cylinders,

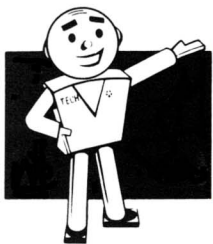

HYDRAULIC BRAKE SYSTEM CONTROLS

Once the master cylinder supplies hydraulic pressure to the brake system, the drum and disc brake systems use different components to regulate pressure or distribute fluid to the front and rear brakes. These components are known as the hydraulic system safety switch, the proportioning valve, and the metering valve. The hydraulic system safety switch is the one of the three that is used on all systems, so let's start with that one.

HYDRAULIC SYSTEM SAFETY SWITCH

The main purpose of the hydraulic system safety switch is to operate a warning light which tells the driver if pressure is lost in either the front or rear brake hydraulic system. Since the front and rear brake hydraulic systems function independently, it is possible that the driver might not notice immediately if pressure and braking is lost in either system. Actually, when a pressure loss is experienced, the pedal travel will be considerably increased and more than usual effort will be required for braking. However, to rule out the possibility of the driver disregarding this condition, the low fluid level warning light is actuated by the hydraulic system safety switch. The other function of the hydraulic system safety switch is to act as a "tee" to the front wheel cylinders. However, this is not true of all systems.

FIVE DIFFERENT SYSTEM APPLICATIONS

There are five different brake system applications

here's a final pointer. When you replace a master cylinder, always check the part number to make sure you're installing the right one. Some master cylinders look alike on the outside, but have different front and rear displacements.

There is a handy chart on the last page which gives the correct part numbers and identifying features for all current brake system applications.

for the hydraulic system safety switch. First, the drum brake system uses only the safety switch. Second, the fixed caliper disc brakes use the safety switch with a proportioning valve behind it. Third, as of the first of January, the fixed caliper disc brake system uses the new combination safety switch and proportioning valve in one unit. Fourth, the floating caliper disc brake system which uses the safety switch with a metering valve ahead of it. Fifth, the floating disc brake system that uses all three – safety switch, metering valve, and proportioning valve. Of course, the later models will have the metering valve and the combination safety switch and proportioning valve. The accompanying chart shows which components are used with the various brake systems for the different body sizes.

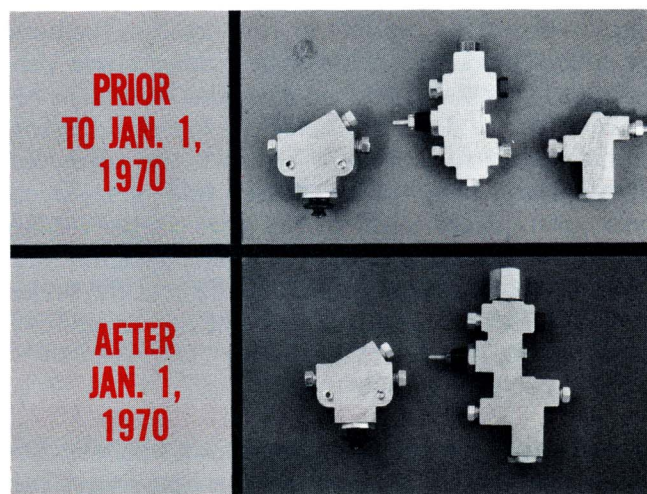

Fig. 16—Switch and proportioning valve combined



BRAKE SYSTEM COMPONENT CHART

Model	Brake Type	Hydraulic System Safety Switch	Proportioning Valve	Metering Valve
Compact	Drum Disc	X *X	X	
Challenger & Barracuda	Drum Disc	X *X	X	X
Intermediates	Drum Disc	X *X	X	X
Full-Size	Drum Disc	X X		X

* Combination Safety Switch and Proportioning Valve after Jan. 1, 1970.

No Proportioning Valves on suburban models

INSIDE THE SAFETY SWITCH

A barbell-shaped, double-headed piston, with an “O” ring on each end, separates the front and rear brake hydraulic systems. Coil springs at both ends keep the piston centered as long as the pressure stays the same in both systems. If pressure is lost in either system, pressure from the other system pushes the piston off-center. When the piston moves far enough to touch the ground contact in the switch, the warning light ground circuit is completed and the light comes on. The springs in the hydraulic system safety switch are quite stiff so that minor variations in pressure will not cause the

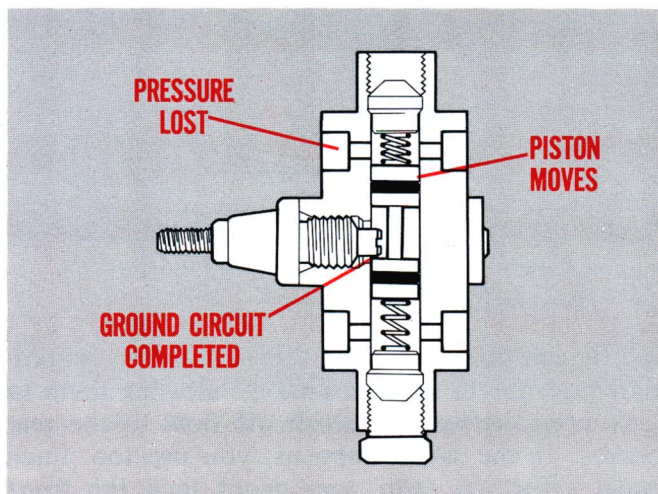

Fig. 17—Minor pressure variations won't move piston

piston to move far enough to touch the ground contact. For example, in a disc brake system, residual pressure in the secondary system will not cause the light to come on even though there is no counteracting residual pressure in the primary.

SAFETY SWITCH OUTLETS

The front brake part of the hydraulic system safety switch has an inlet and two outlets. As mentioned earlier, the safety switch functions as a “tee” to the front brakes in some applications. However, for systems using the metering valve, one of the outlets is plugged. You'll see why when the metering valve is discussed. The rear brake part has an inlet and only one outlet. Different size tube connectors are used here, the same as on the master cylinder, to prevent incorrect brake line connections.

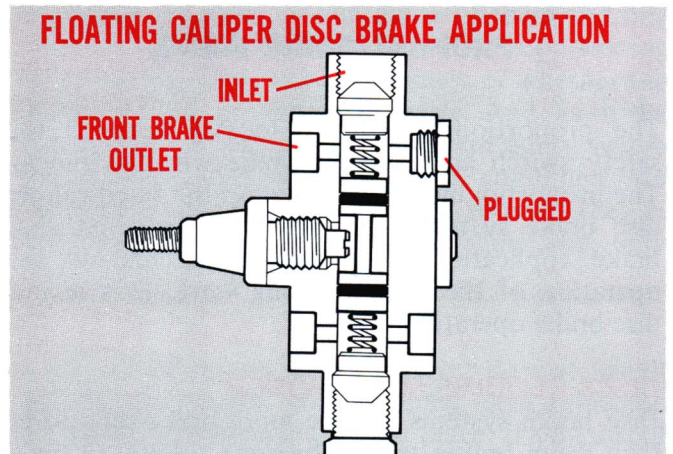

Fig. 18—In this case, switch doesn't act as a “tee”

TEST THE BULB, THEN THE SWITCH

It's pretty simple to test the hydraulic system safety switch; but *test the warning light bulb first*. Apply the parking brakes with the ignition on. One light does two jobs, so the bulb is “proofed” or tested every time the parking brake is applied with the ignition on. Then, have someone apply the service brakes and watch the warning light while you momentarily open a front, and then a rear, bleeder screw. If the light doesn't come on, install a new switch. There's one very important thing to remember if you have to install a new hydraulic system safety switch. Make sure you don't install one of the new ones with the integral proportioning valve if there wasn't one there in the first place. You'll see why when we discuss the proportioning valve in detail.

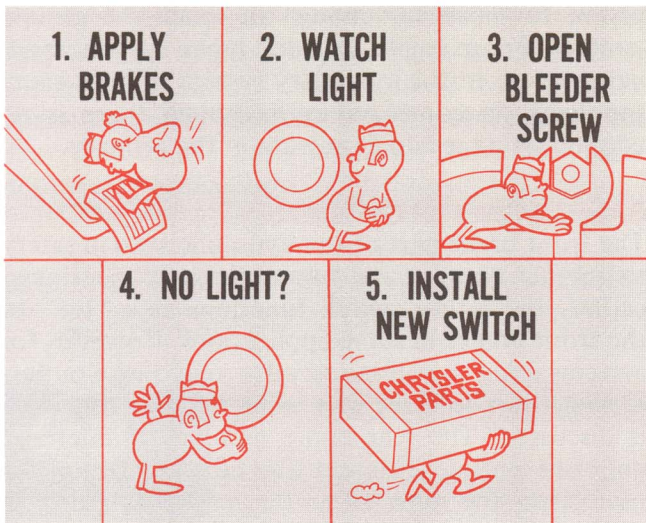

Fig. 19—Test warning light with parking brake, first

PROPORTIONING VALVE

The proportioning valve is located between the safety switch and the rear brake wheel cylinders. The proportioning valve is used on the fixed caliper disc brake system and some floating caliper disc brake applications. To properly understand the operation of the proportioning valve, let's review disc brake operation.

DISCS REQUIRE MORE FORCE

Disc brake systems require more brake-shoe force than drum brakes to get the same amount of braking action. The proportional area of the front and



Fig. 20—Tire traction reduced by weight shift

rear brake pistons is such that equal pressure front and rear will produce balanced braking on normal applications. However, in a hard stop, disc brake piston force must be quite high to get proper braking action. Because rear tire traction is reduced by a weight shift in a sudden stop, the rear brakes tend to lock up prematurely from a high-pressure application.

THE PROPORTIONING VALVE

On all fixed caliper systems and intermediate models with floating caliper systems, a proportioning valve operates when the hydraulic pressure reaches a certain point to retard or proportion the pressure build-up in the rear brake lines and wheel cylinders. On light pedal applications, the valve simply lets brake fluid flow through it to the rear brakes. On hard brake applications, system pressure naturally climbs higher. Above three-hundred p.s.i., a spring-loaded sliding piston in the valve moves against the spring pressure to proportion rear system pressure to about fifty percent of the pressure to the front brakes. This way the valve provides a pressure difference to keep front and rear braking forces in balance.

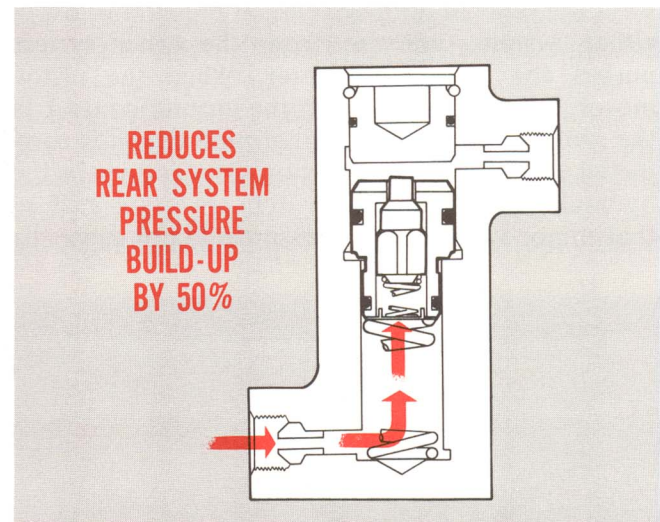

Fig. 21—Pressure is reduced above 300 p.s.i.

IF THE PROPORTIONING VALVE IS BAD . . .

. . . it can do one of two things — fail to proportion pressure to the *rear brakes*, allowing them to lock prematurely; or, block off flow to the rear brakes. If the latter happens, you use too much pedal effort to stop, you might lock the *front brakes*.

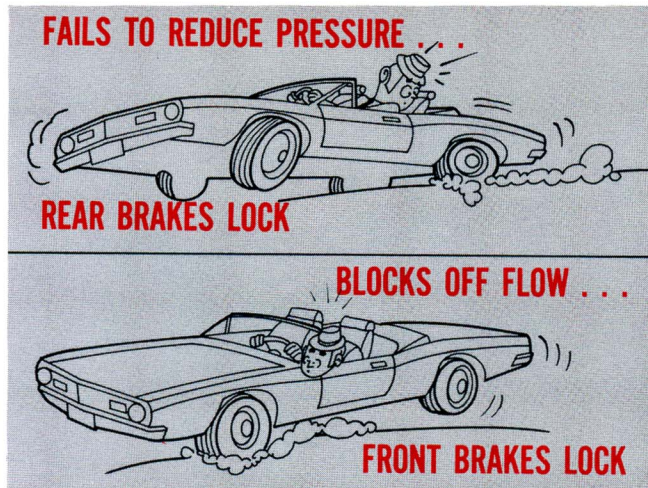

Fig. 22—These are results of bad proportioning valve

YOU'LL NEED GAUGES TO TEST THIS ONE

To test the proportioning valve, install a pressure gauge (Tool C-4007) in the brake line between the master cylinder and the proportioning valve. Install the other gauge at the output end of the valve. Have someone push on the brake pedal hard enough to get a master cylinder output of approximately 500 p.s.i. While holding 500 p.s.i. master cylinder pressure the gauge on the valve output should read between 350 and 400 p.s.i. If pressure reading does not meet specifications, remove the valve and install a new one.

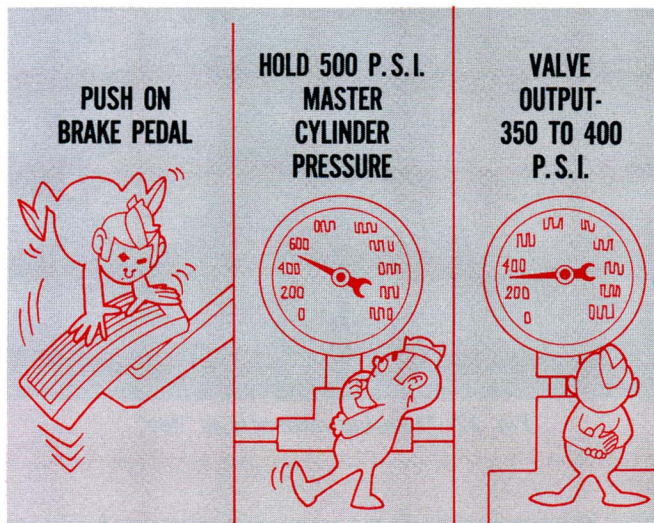

Fig. 23—You'll need a helper for this test

MAKE SURE YOU USE THE RIGHT VALVE

In the past there has been more than one type of

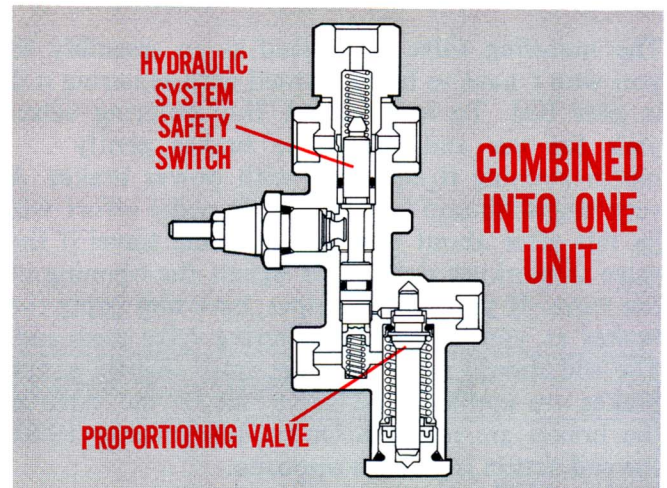

Fig. 24—In production as of January 1, 1970

proportioning valve — one made of brass and one made of cast iron. If you replace a proportioning valve, use the brass type, regardless of whether the car had a brass or a cast-iron valve. And, as of the first of the year, the hydraulic system safety switch and proportioning valve have been combined into one unit. Don't let it throw you though, they're still the same parts and work the same way, only they're both in one housing.

YOU DON'T NEED TWO VALVES

If you install a new safety switch, do not install one with the integral proportioning valve unless the car was so equipped in the first place. If you install a combination switch and proportioning valve on a brake system that doesn't require a proportioning valve, you'll get pressure regulation to the rear brakes when it isn't necessary. If you install the combination switch and valve on a model that has a separate proportioning valve, you'll have two valves regulating pressure to the rear brakes which will further limit braking power at the rear wheels.

FLOATING CALIPER DISC BRAKES NEED METERING VALVE

The floating caliper disc brakes on full-sized cars are designed for excellent balance with the rear drum brakes. However, on intermediate models it is desirable to *reduce* front wheel braking on icy or extremely slippery road conditions. The metering valve cuts off pressure to the front brakes in the ten to one-thirty-five p.s.i. range.

SERVICE AND TESTING

The metering valve is serviced as an assembly so you won't have to be concerned with repairing it if it goes bad. To quick-check the metering valve, park the car and apply the brakes gently . . . motor running if equipped with power brakes. A very slight "bump" or change in pedal effort will be felt after about one inch of pedal travel if the valve is working right. This signals the opening of the valve. If you have a helper, have him apply the brakes as you watch the metering valve push rod. The rod should move into the valve slightly as the brakes are applied, and move out of the valve as the brakes are released. On models prior to 1970, the rod action is just the opposite.

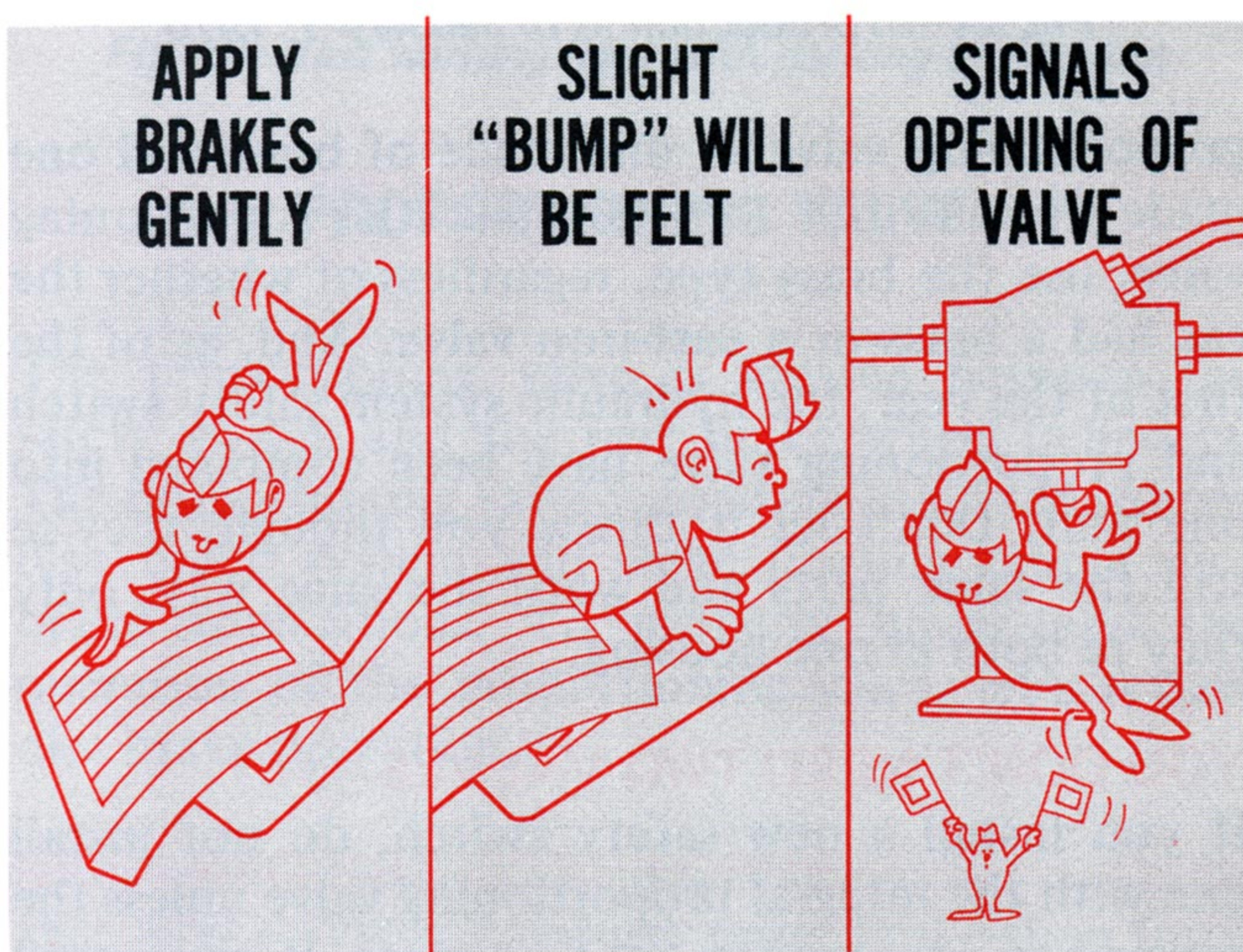

Fig. 25—Bump will be felt after about one inch travel

BLEEDING WITH METERING VALVE

Gravity bleeding is preferred on disc brake systems; but if you use a pressure bleeder on a system with a metering valve, be sure to keep the metering valve open. That's because pressure bleeders are usually operated at about 30 p.s.i. and this pressure will close the metering valve and shut off flow to the front brakes. Use tool C-4121 to hold the push rod open while bleeding the brakes. On earlier models, hold it open by hand or tape it open. And don't forget to remove the tool or tape when you're through. If you happen to forget, full pressure will act on the diaphragm inside when the brakes are applied. This could rupture the diaphragm and result in a ruined metering valve. While we're on the subject, if you replace *any* component, or disconnect *any* line in the system, you'll have to bleed the brake system after you reconnect the lines. Don't overtorque the fittings; and a good way to

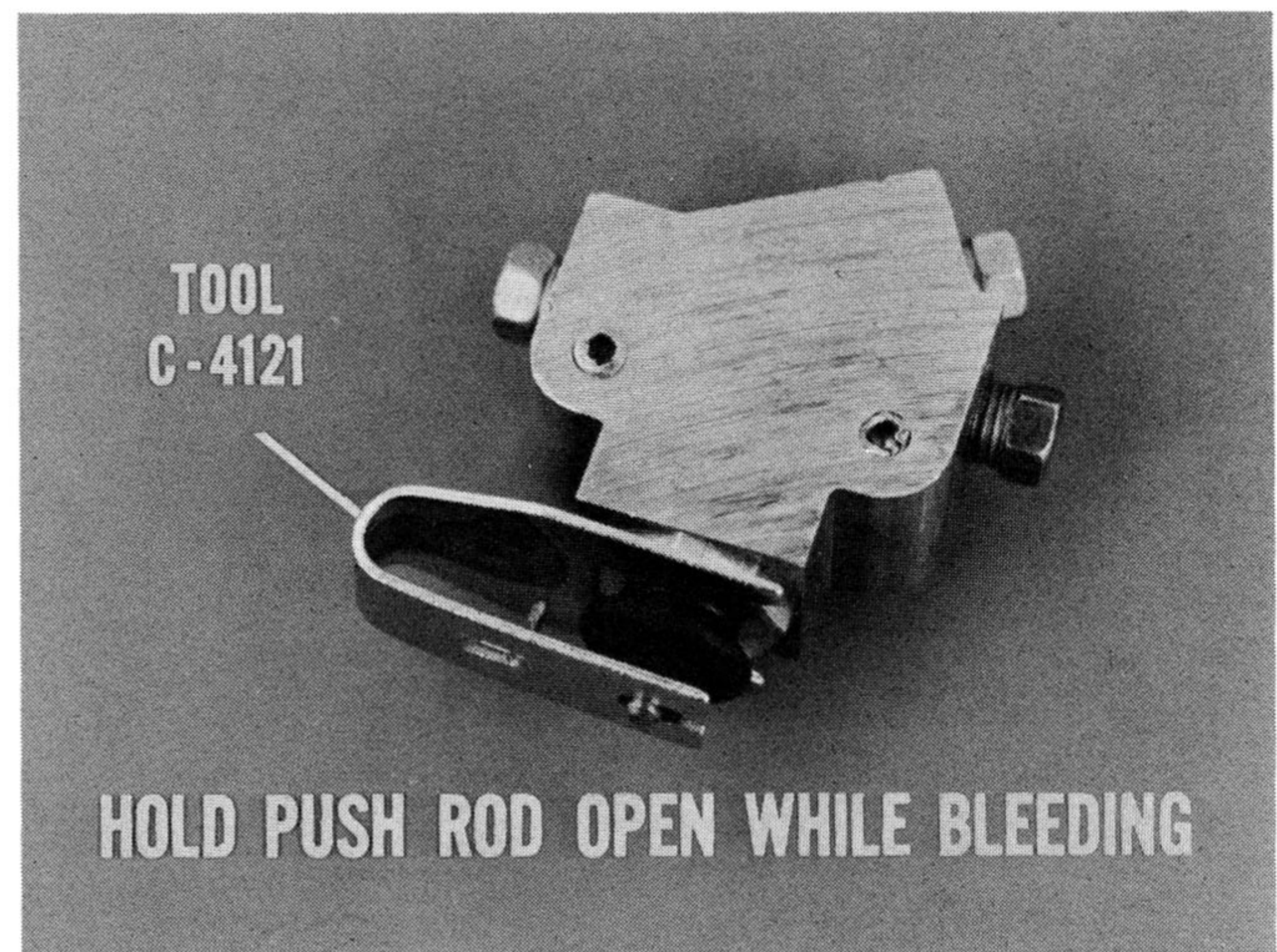

Fig. 26—Be sure to remove tool after test

avoid damaging the tube nuts and brass seats is to use special wrenches designed for tube nuts.

A FINAL NOTE TO AVOID CONFUSION

The *proportioning* valve is located between the *safety switch* and the *rear* brakes. The *metering* valve is located between the *safety switch* and the *front* brakes. That's why one of the outlets is *plugged* on the safety switch when used with a metering valve. The metering valve acts as the "tee" for fluid distribution to the front brakes.

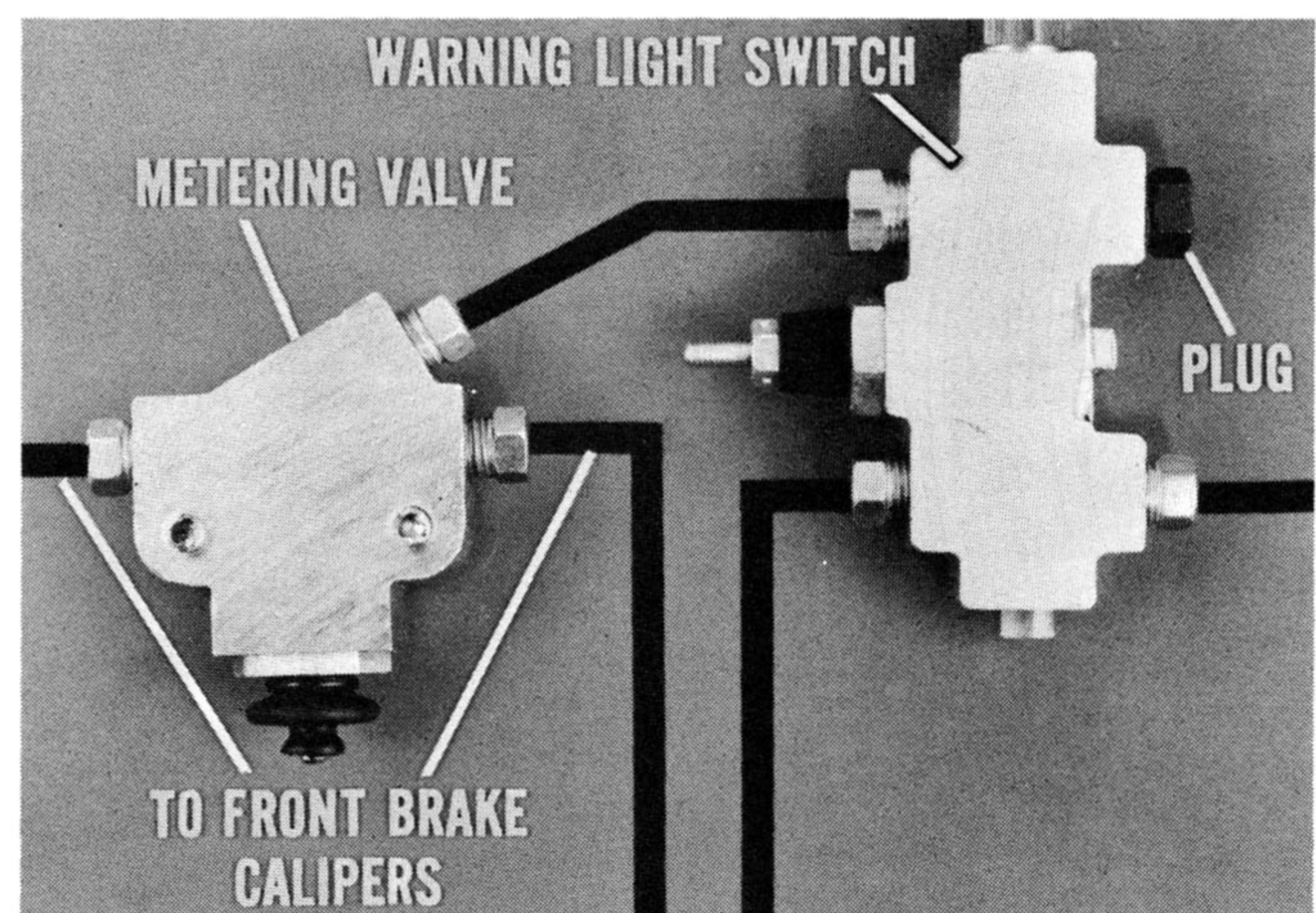

Fig. 27—Metering valve acts as "tee"

REMEMBER THIS, TOO

The *proportioning* valve regulates pressure build-up to the *rear* brakes to minimize rear wheel skids on hard brake applications. The *metering* valve holds off pressure to the *front* brakes under *light* braking to minimize front wheel skids on icy or wet surfaces.

1970 MODEL REPLACEMENT MASTER CYLINDER IDENTIFICATION CHART

Brake Type	Replacement Cylinder Package Part No.	Cover Retainer	Line Connections	Bore End Stamp
V, L - Drum Manual & Power	3420961	Bolt	Outboard	None
B, J - Drum Manual Only	3420961	Bolt	Outboard	None
All Other Drum Manual & Power	2808577	Bolt	Outboard	None
V, L - Disc	2808600	Bail	Outboard	A
R, W - Disc (Taxi) Manual	2944479	Bail	Outboard	None
B, J - Disc (Exc. 426 Eng.)	2944453	Bail	Outboard	B
R, W - Disc (Exc. 426 Eng.)	2944477	Bail	Inboard	D
B, J, R, W - Disc (With 426 Eng.)	2944476	Bail	Outboard	B
P, D, C, Y - Disc	2883089	Bail	Outboard	None
Model Code: J - Challenger B - Barracuda	V - Valiant L - Dart	R - Belvedere W - Coronet	P - Plymouth D - Dodge	C - Chrysler Y - Imperial

**Master
Technician** 
**customer
care**